

No. 364 Cutter

**NOTE: Order parts by Catalog Number only.
DO NOT order by Reference Number.**

Ref. No.	Catalog No.	Description
—	34617	364 Cutter Complete
1	36287	Feed Screw Handle
2	36292	Cutter Frame
3	45505	Support Arm
4	45520	Hinge Pin
5	35317	Retaining Pin
6	46662	Roll Pin (2)
7	46960	Roll (Steel) (2)
8	43682	Roll Pl. Coated Pipe (2)
9	44185	Cutter Wheel E-1032
10	34780	Wheel Pin
11	36282	Wheel Housing

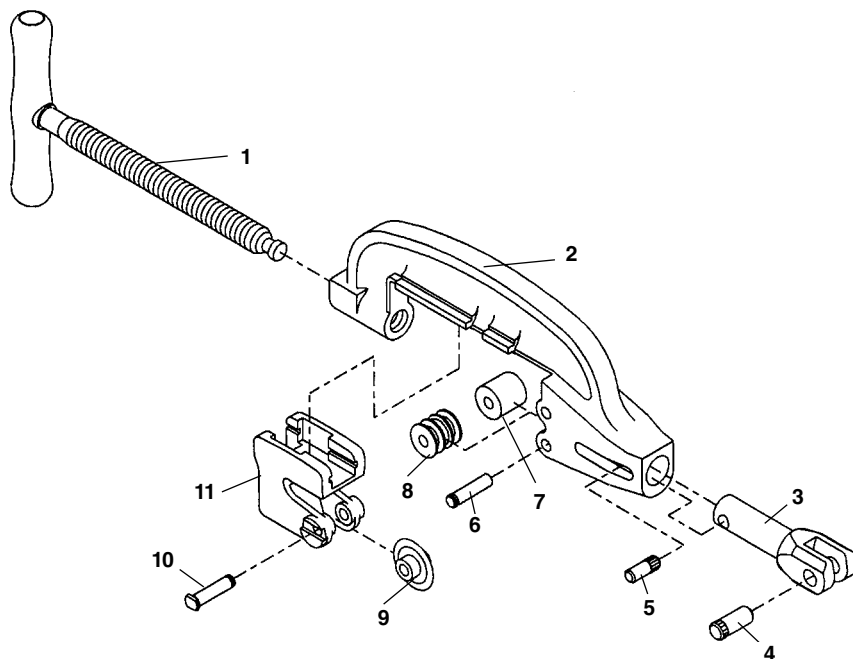

No. 344 Reamer

Ref. No.	Catalog No.	Description
—	34612	344 Reamer Complete
1	36262	Shoulder Screw
2	36267	Pivot Pin
3	36272	Reamer Arm
4	36277	Reamer Cone (R.H.)
	46660	Reamer Cone (L.H. & R.H.)
5	35355	Split Roll Pin

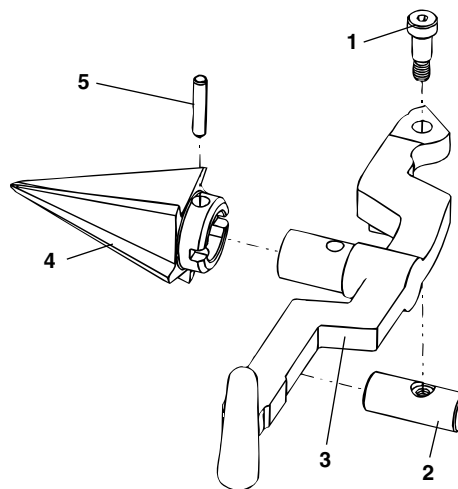

No. 839 Nipple Chuck

Ref. No.	Catalog No.	Description
—	35867	No. 839 Adapter Kit
1	54307	Drive Screw (6)
2	47502	Roll Pin
3	47507	Tube Assembly
4	47512	Pin, 3/4" x 2 3/4"

